

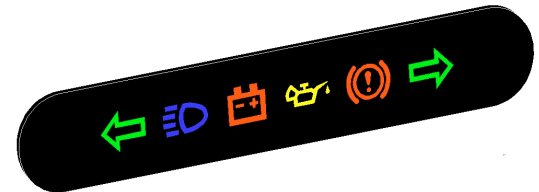

BRIGHT6 INSTRUCTIONS



Thank you for purchasing the Bright6 warning light module. This product brings a production vehicle class finish to the aftermarket.

- The very latest LED technology has been used to create a high contrast and definition warning light module.
- Easy to install: Only 8 wires to connect, instead of 12.
- 6 backlit symbols on a self-adhesive black textured fascia panel.
- Longer life than incandescent lamps.
- Temperature range: 0°C to +40°C.
- Operating Voltage: 9 to 16 Volts.
- Viewing angle: 30° included.

There are two ways to mount the unit within a dashboard. You can have the fascia panel situated either in front of, or behind the dash. The fascia panel has a permanent adhesive selectively applied to allow it to bond to any flat smooth non-porous surface.

Installation:

Figure 1 shows a cross section through the dashboard and Bright6 module, with a front-mounted fascia panel.

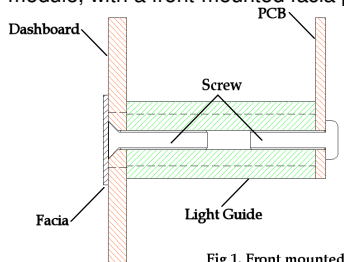

Fig 1. Front mounted

Figure 2 shows a cross section through the dashboard and Bright6 module, with a rear mounted fascia panel.

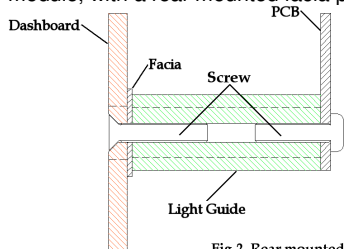

Fig 2. Rear mounted

Removing the adhesive backing paper and fixing to the dashboard: Ensure the surface is clean, dry, oil free, smooth and non-porous. Electrically connect the Bright 6 module as detailed above to illuminate all warning lights. This will aid in alignment, so there's no obscuration of any part of a symbol. Mark-out the area with masking tape, remove the adhesive backing and apply from one end, using a

clean lint-free cloth to gently press the fascia panel onto the dashboard surface. The adhesive is pressure sensitive, which means the bond is stronger when pressed harder, but be careful you don't push into the symbol holes and deform the fascia panel. Note: For a rear mounted fascia panel it will be necessary to pierce the fascia panel to allow the mounting screws to pass through.

General Notes:

Ensure the PCB is upper most as the fascia will only be correct one way round.

We recommend you drill 8.5mm diameter holes on a 10mm pitch into your dashboard for each warning light. Alternatively you could form an oval hole for a rear-mounted installation (do not use an oval hole for a front-mounted installation, as the webs between the 8.5mm holes are required to support the fascia panel. See figure 3 for drilling information.

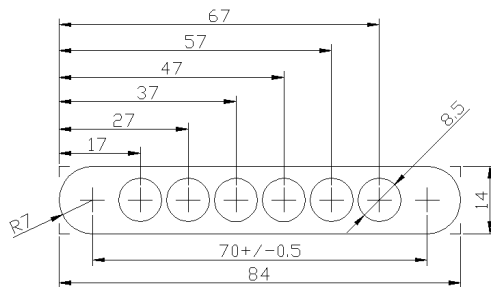

Positional accuracy of mounting holes +/-0.5mm

Fig 3. Drill dimensions

Note: Measure the mounting hole pitch before drilling your dashboard, countersunk screws, will centralise to the holes drilled.

Electrical Installation:

Warning: Incorrect connection will result in damage to the module.

Wire Colour	Function	To test connect: **	Light Colour
Green	+12V Ignition	+12V	N/A
Black	Chassis Earth	0V	N/A
Green/Red	Left Indicator	+12V	Green
Blue/White	Main Beam	+12V	Blue
Brown/Yellow	Ignition/Charge to DF on Alternator	0V	Red
White/Brown	Oil Pressure to switch in block.	0V	Yellow
Black/White	Fluid Low to brake reservoir.	0V	Red
Green/White	Right Indicator	+12V	Green

** Note: for test, the module must be disconnected from the vehicle.

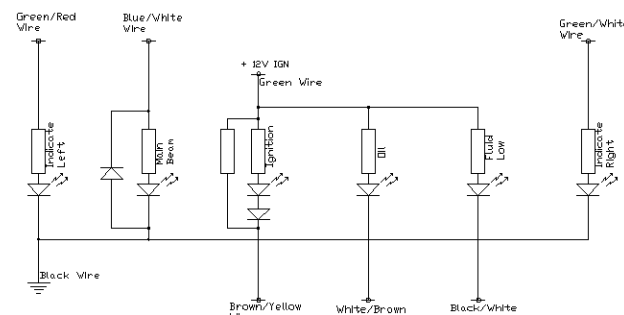

Figure 4. Circuit Diagram

The Ignition/Charge warning Light has circuitry to ensure correct operation of any alternator, which is normally connected through an incandescent bulb, to a +12V Ignition feed.

Ensure all electrical feeds are correctly fused and wires are terminated using insulated connectors. The electrical integrity is your responsibility. If you are in any doubt, consult a qualified auto-electrician.

Replacement fascia panels are available separately under the Part number LLDES003b.

Also available from Lightning Looms Ltd:

- BRIGHT6T: a "T-shaped" version of the BRIGHT6 with additional features. Designed to nestle between two instruments. Measures only 50 x 50 x 32mm.
- BRIGHT6T BIKE: as above. Replaces ignition light with Neutral gear indicator light.
- Dimming Kit: Resistors, parts and instructions to permanently dim main beam, and indicator warning lights.
- Fitting Plate: Laser cut plate to aid BRIGHT6 fitment to padded dashboards.

Currently under development:

- Bright6 Bezel: Chrome plated or powder coated bezel.
- Bright6 Auto-dimming modules: Dims main beam and indicators when sidelights are switched on. (prototypes are on field trials)
- Integrated Dashboard Switching Modules: Combines dashboard switches with fuses, relays, connectors and additional features. Check our website for released details.