

BRIGHT6T BIKE INSTRUCTIONS

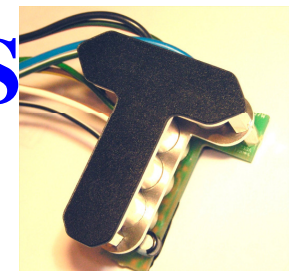

Thank you for purchasing the new Bright6T Bike warning light module. This product brings a production vehicle class finish to the aftermarket.

Improvements over the standard Bright6 module:

- Secret until lit fascia. Symbols are just visible when off.
- Light guide tube has polished bore, which increases viewing angle.
- Fluid low lamp test feature at Ignition on.
- Surface mount components allow a PCB not much bigger than the fascia.

Standard features:

- The very latest LED technology has been used to create a high contrast and definition warning light module.
- Only 8 wires to connect, instead of 12.
- 6 backlit symbols on a self-adhesive black textured fascia panel.
- Longer life than incandescent lamps.
- Easy to install.
- Temperature range: 0°C to +40°C.
- Operating Voltage: 9 to 16 Volts.
- Viewing angle: 40° included.

The fascia panel has a permanent adhesive selectively applied to allow it to bond to any flat smooth non-porous surface. For wooden and padded dash panels a range of fitting accessories are available. Please ask for details

Installation:

Figure 1 shows a cross section through the dashboard and Bright6T Bike module with fascia panel fitted.

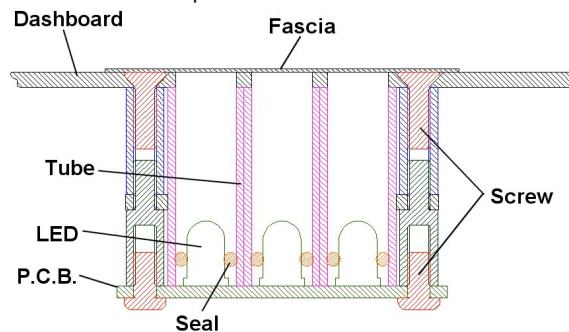

Figure 1 Cross Sectional View

Removing the adhesive backing paper and fixing to the dashboard: Ensure the surface is clean, dry, oil free, smooth and non-porous. Electrically connect the Bright6T Bike module as detailed in the "Electrical Installation" section to illuminate all warning lights. This will aid in alignment, so there's no obscuration of any part of a symbol. Mark-out the area with masking tape, remove the adhesive backing and apply from one end, using a clean lint-free cloth to gently press the fascia panel onto the dashboard surface. The adhesive is pressure sensitive, which means the bond is stronger when pressed harder, but be careful you don't push into the symbol holes and deform the fascia panel.

General Installation Notes:

We recommend you drill 8mm diameter holes on a 10mm pitch into your dashboard for each warning light. See Figure 2 for drilling information.

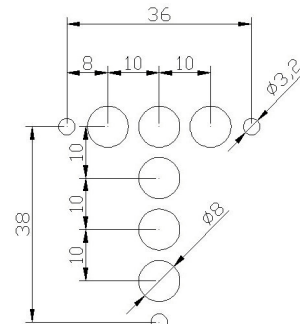

Figure 2. Drill dimensions

Electrical Installation:

Warning: Incorrect connection will result in damage to the module.

Wire Colour	Function	To test connect: **	Light Colour
Green	+12V Ignition	+12V	N/A
Black	Chassis Earth	0V	N/A
Green/Red	Left Indicator	+12V	Green
Blue/White	Main Beam	+12V	Blue
Grey	Neutral Light	0V	Green
White/Brown	Oil Pressure to switch in block.	0V	Yellow
Black/White	Fluid Low to brake reservoir.	0V	Red
Green/White	Right Indicator	+12V	Green

** Note: for test, the module must be disconnected from the vehicle.

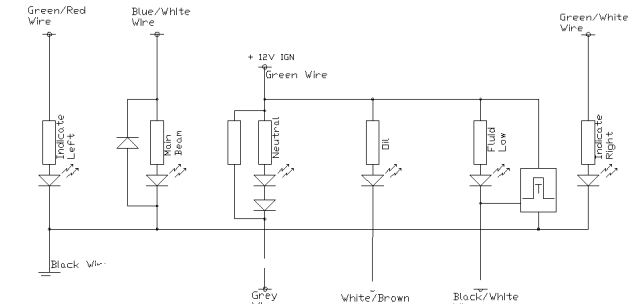

Figure 3. Circuit diagram

The fluid low symbol has a lamp test feature built-in. When the ignition is switched on the fluid low symbol will illuminate for a second. Note: This feature takes up to 3 minutes to fully reset. If the ignition is switched off and on quickly, the light will illuminate, but not for the full second.

Brightness can be adjusted using optional resistors, which are available separately.

The following accessories are under development:

- Auto night dimming module. Indicators and main beam lights dim when sidelights switch on.
- Wooden dashboard fitting kit.
- Padded dashboard fitting kit.
- Mounting bezel in either Chrome or powder coat finish.

Ensure all electrical feeds are correctly fused and wires are terminated using insulated connectors. The electrical integrity is your responsibility. If you are in any doubt, consult a qualified auto-electrician.

Replacement fascia panels are available separately under the Part number LLDES006-001. Please ring for a price. Please note we will only supply replacements upon receipt of a damaged fascia panel, or with proof of purchase.

E&OE. ©2007 Lightning Looms Ltd. Issue 1.0